

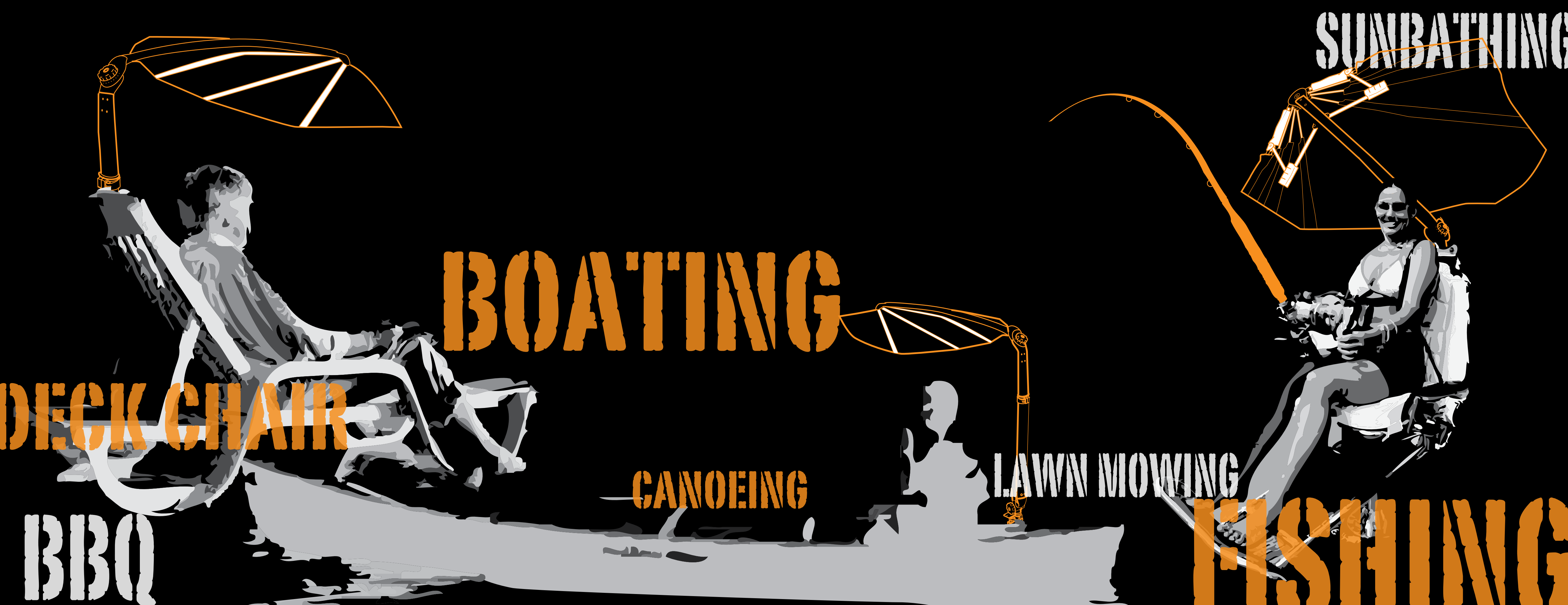

1 CHOOSE YOUR LEISURE ACTIVITY



SUNBATHING

BOATING

DECK CHAIR

BBQ

CANOEING

LAWN MOWING

FISHING

2

CHOOSE A MOUNT

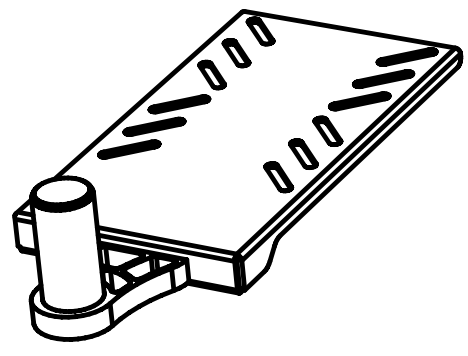
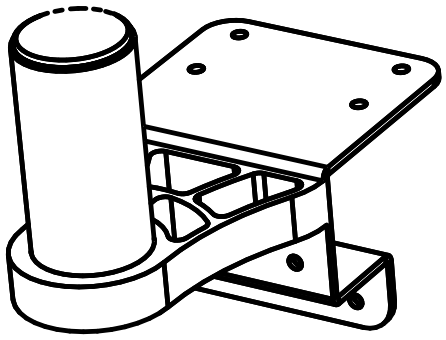
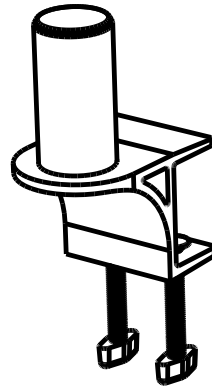
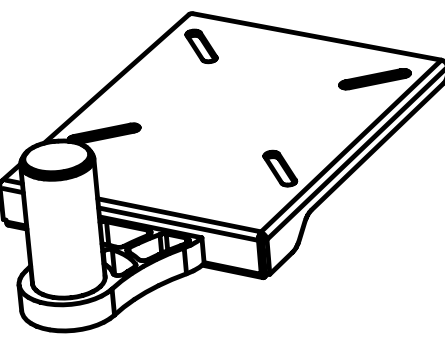
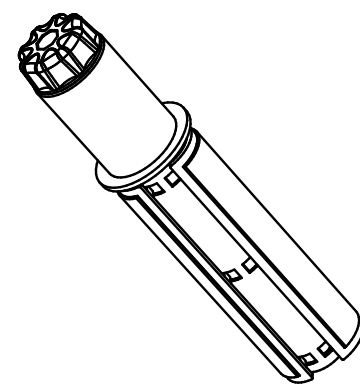
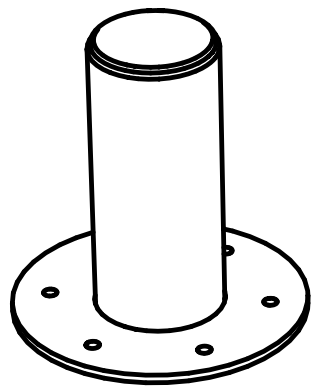
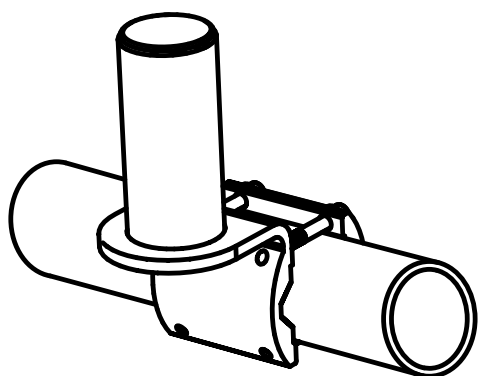
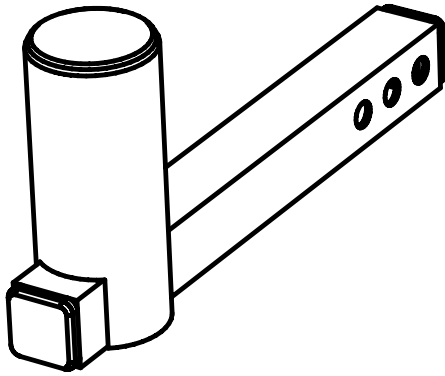
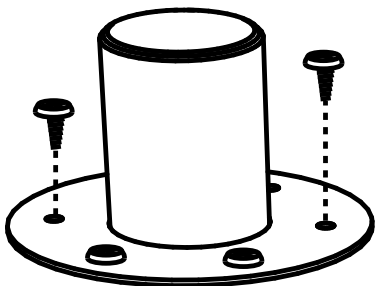
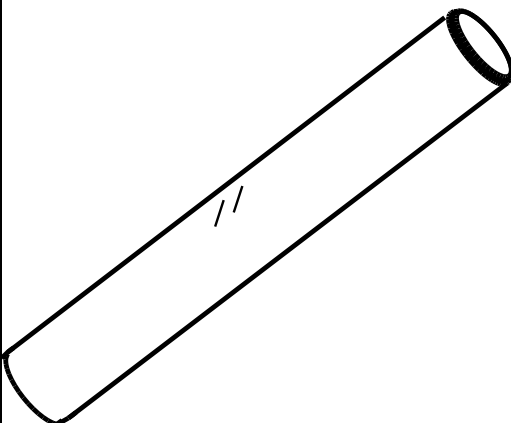
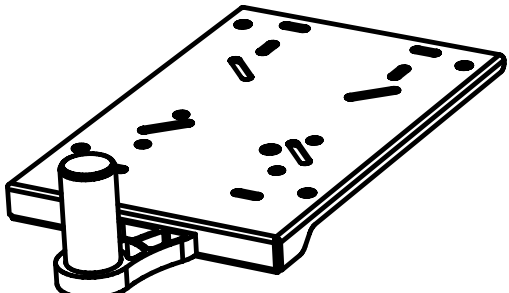
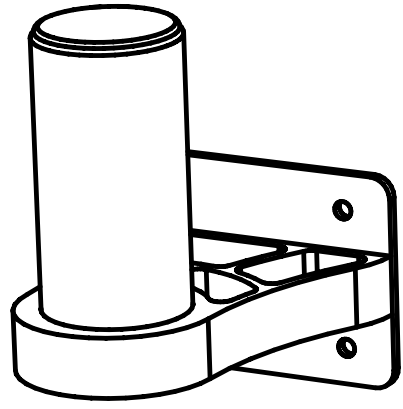
		
SWIVEL SEAT	BENCH MOUNT	CLAMP
		
BUTT SEAT	ROD HOLDER	DECK FLOOR
		
RAIL MOUNT	SCOOTER MOUNT	FLUSH MOUNT
		
UMBRELLA MOUNT	SLIDER SEAT	SIDE/WALL

3

CHOOSE A MANTIS

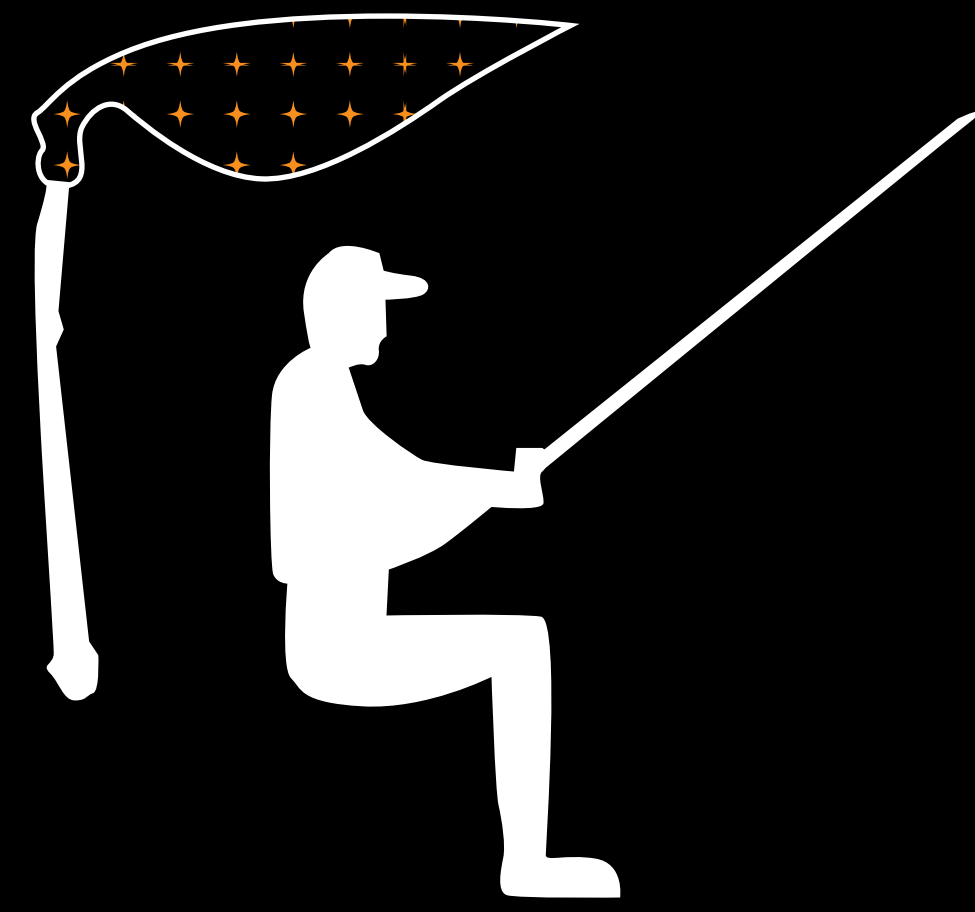

ORIGINAL

Mount level with seat or lower

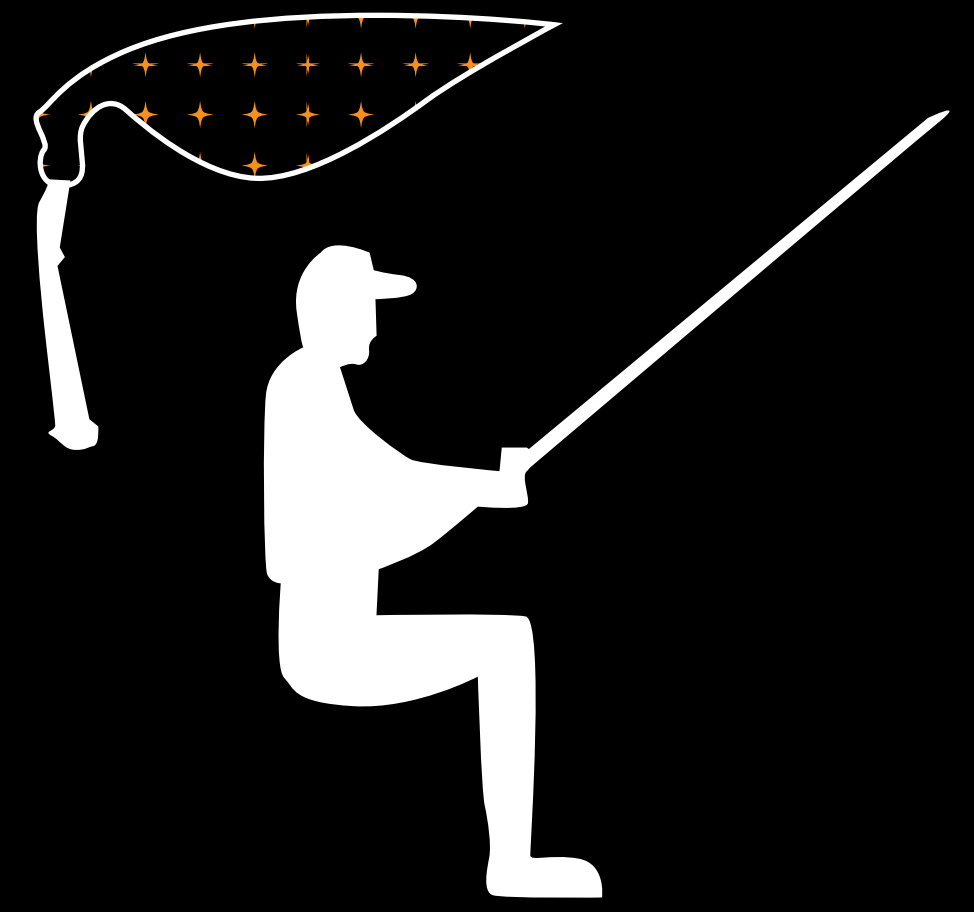

JUNIOR

Mount level with mid back

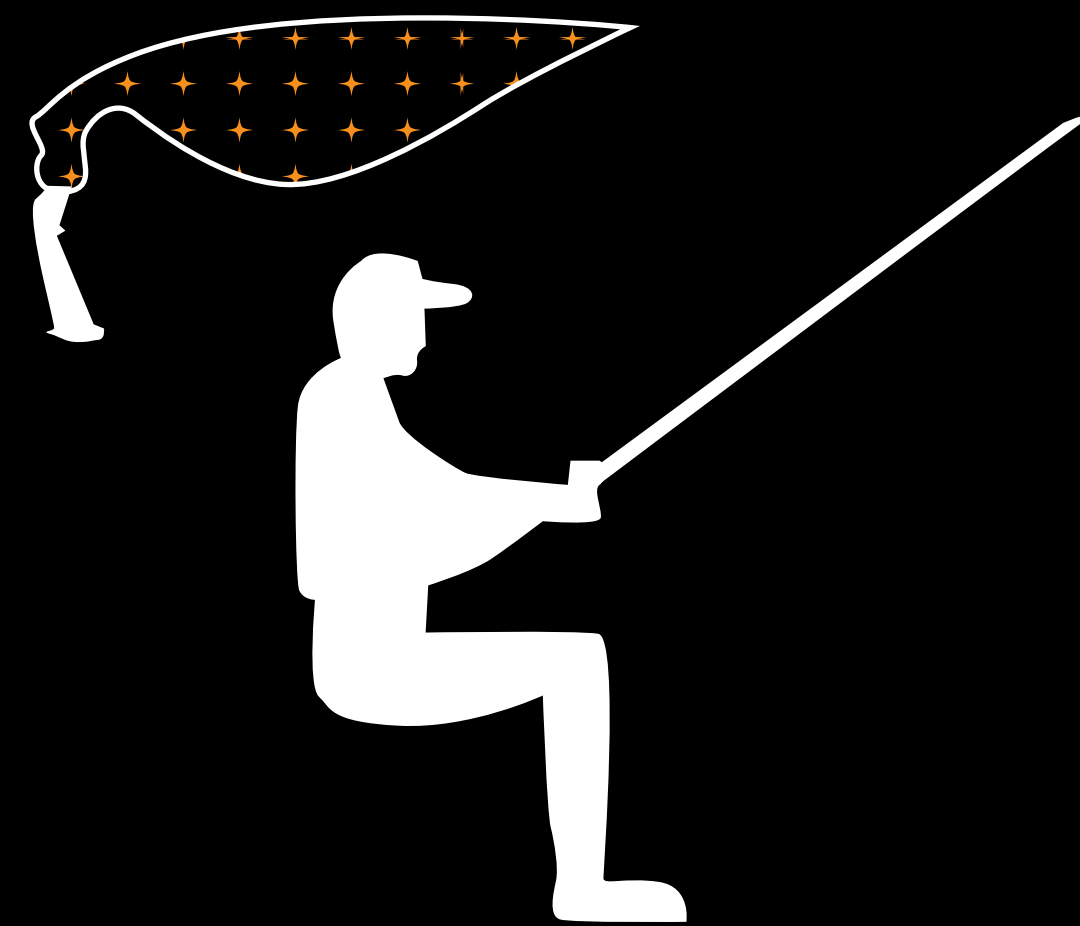

SHORTIE

Mount level with neck or higher

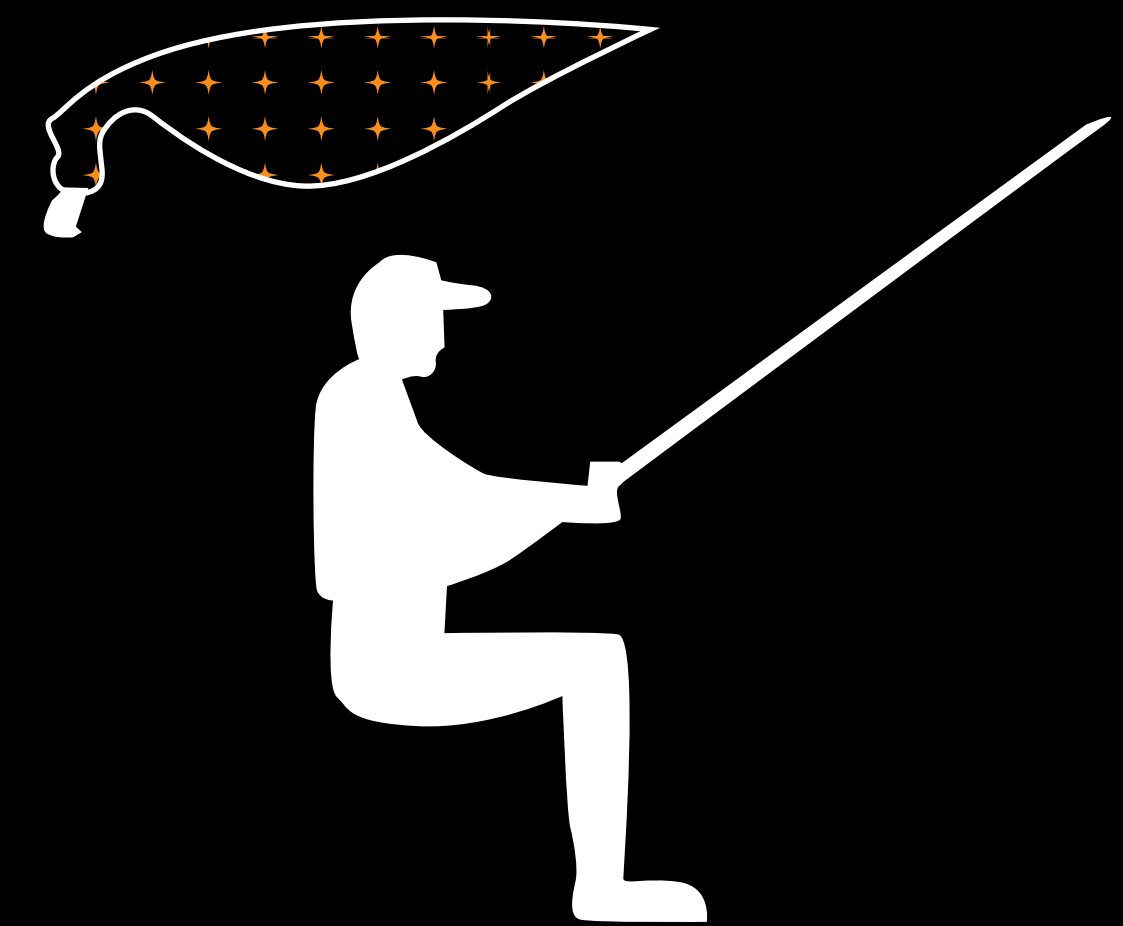

EXTENDER

Mount level with mid - head

4

CHOOSE A COLOUR



The Mantis is constructed with award-winning Sunbrella fabrics in a wide range of colours.

Fade-resistant Sunbrella fabrics have a high degree of UV protection and resistance from salt water and all kinds of weather conditions. Complete with a 5 year fabric warranty.



* Polyester Version Available in 3 colours: Charcoal, Forest Green, Pacific Blue

MANTIS FEATURES

5

SPANS APPROX 1.4M WIDE



POWDER - COATED ALUMINIUM SPINES (UPPER & LOWER)

INFINITE ANGLE ADJUSTMENT

12 CUSTOM DESIGNED MOUNTS WITH EASY ON-OFF ATTACHMENT

AVAILABLE IN GENUINE SUNBRELLA FABRICS IN A RANGE OF COLOURS

HEIGHT ADJUSTMENT

UV, MILDEW & ROT RESISTANT FABRICS REMOVES QUICKLY AND EASILY FOR CLEANING

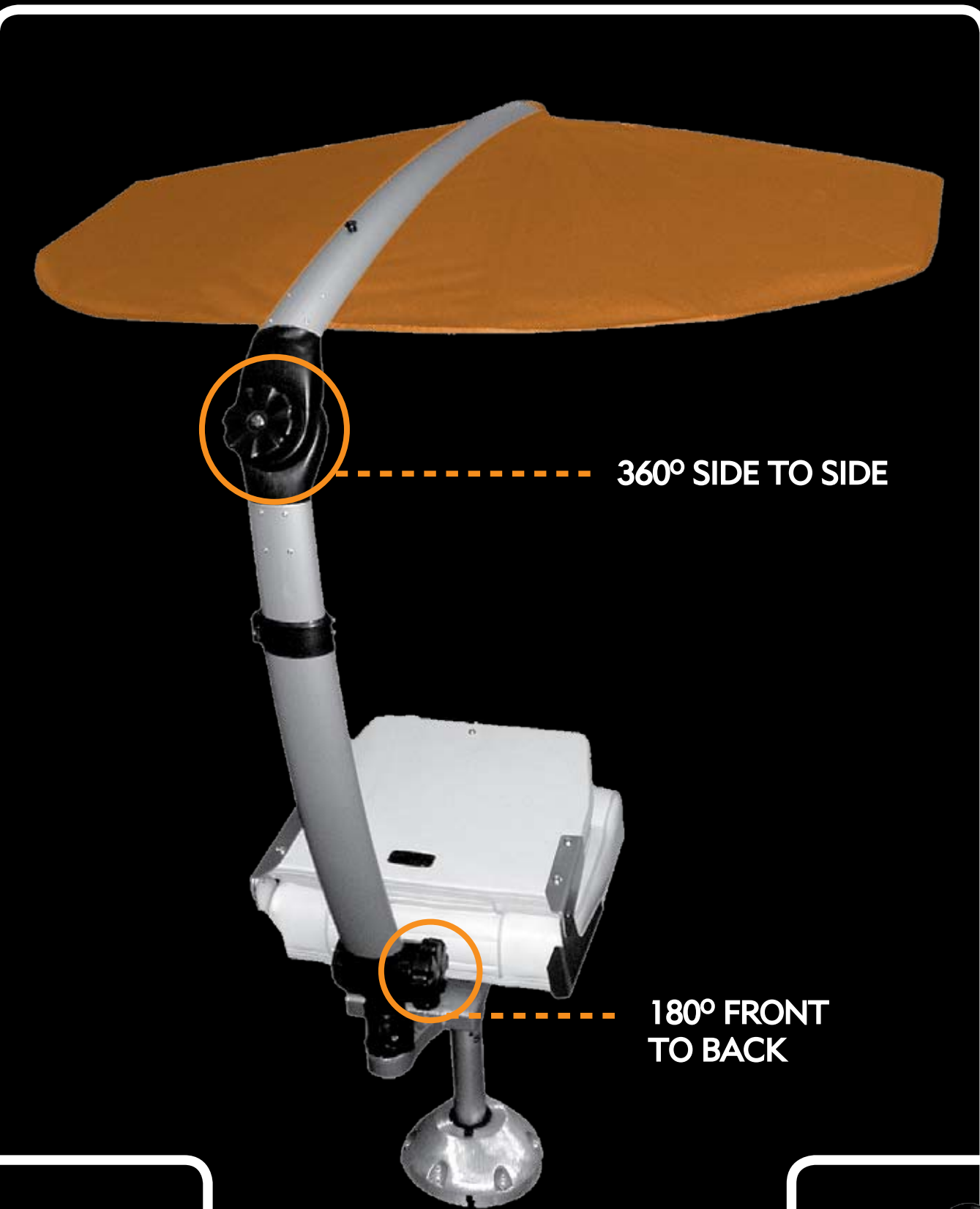

360° SIDE TO SIDE

180° FRONT TO BACK

Note: boat seat and pedestal not included



ELASTIC LATCH FOR SECURE STORAGE



QUICK LOCKING HINGE FOR EASY DEPLOYMENT

STORES COMPACTLY
96 X 13 X 15 CM
WEIGHS 2.2-3.2 KGS